



DTM-151
DIGITAL TESLAMETER
with serial communications
USER'S MANUAL

For units supplied with software DTMS V6.0 & V7.0

20 July 2007

Thank you for purchasing and using a Group3 digital teslameter. We hope you will join the many hundreds of users worldwide who are enthusiastic about our products.

Group3 has been designing and building magnetic field measuring equipment since 1983. We are constantly upgrading our products and support documentation. We welcome input from our customers, so if there are aspects of the instrument which you particularly like, or which you would like to see improved, please contact your Group3 supplier (see back page for a complete list) or Group3 directly with your suggestions to **info@group3technology.com**.

The Group3 website, **www.group3technology.com** contains details of all our products. This site is regularly updated, so check it from time to time to learn about recent developments.

Group3 Technology Ltd.
2 Charann Place, Avondale, Auckland 1026
PO Box 71-111, Rosebank, Auckland 1348, New Zealand.
Phone: +64 9 828 3358
Fax: +64 9 828 3357
Email: info@group3technology.com
Web: <http://www.group3technology.com>

CONTENTS

1. General Description	1-1
2. Specifications of DTM-151 System	2-1
3. Setting Up	
3.1 Introduction	3-1
3.2 Connecting the Hall Probe	3-1
3.3 Connecting the Power Source	3-2
3.4 Fiber Optic Connections	3-4
3.5 Electrical Serial Data Input/Output Connections	3-4
3.6 Internal DIP Switch Settings	3-9
3.7 Bit Rate Selection	3-12
3.8 Second Watchdog Operation	3-13
3.9 Analog Outputs	3-15
3.10 Grounding	3-16
3.11 Installing the Panel Mount Option	3-17
3.12 Installation Techniques for Electrically Noisy Environments	3-18
4. Operating Instructions	
4.1 Zeroing	4-1
4.2 Installing the Probe	4-2
4.3 Reading the Field Value	4-3
4.4 Display Modes, Using the Front Panel Keys	4-4
4.5 Using the Serial Data Inputs & Outputs	4-7
4.6 Digital Filtering	4-14
4.7 Triggered Operation	4-15
5. Technical Diagrams	
General Information	5-1
Display Board Schematic	5-2
Display Board Component Overlay	5-3
Display Board Parts List	5-3
Probe Plug Board Schematic	5-4
Probe Plug Board Component Overlay	5-5
Probe Plug Board Parts List	5-5
Processor Board Schematic	5-6
Processor Board Component Overlay	5-7
Processor Board Parts List	5-8
Analog Board Schematic	5-9,10
Analog Board Component Overlay	5-11
Analog Board Parts List	5-12,13

LIST OF FIGURES

Fig. 1 Power Input Connections of the -L option	3-3
Fig. 2 RS-232-C Connector & Jumper Locations	3-6
Fig. 3 Send and Receive Jumpers	3-8
Fig. 4 Option Jumpers	3-8
Fig. 5 Location of Processor Board Switches	3-10
Fig. 6 Location of Second Watchdog Select Jumper	3-13
Fig. 7 Panel Cutout Dimensions	3-17
Fig. 8 Probe Dimensions	4-3
Fig. 9 G3CL - Alternative Configurations	4-8
Display Board Schematic	5-2
Display Board Component Overlay	5-3
Display Board Parts List	5-3
Probe Plug Board Schematic	5-4
Probe Plug Board Component Overlay	5-5
Probe Plug Board Parts List	5-5
Processor Board Schematic	5-6
Processor Board Component Overlay	5-7
Processor Board Parts List	5-8
Analog Board Schematic	5-9,10
Analog Board Component Overlay	5-11
Analog Board Parts List	5-12,13

LIST OF TABLES

Table 1	G3CL Connector Pin Assignments	3-5
Table 2	RS-232-C Connector Pin Assignments, Terminal Mode	3-7
Table 3	RS-232-C Connector Pin Assignments, Modem Mode	3-7
Table 4	DIP Switch Functions	3-10
Table 5	Serial Data Format Switch Settings	3-11
Table 6	String Terminator Switch Settings	3-11
Table 7	Bit Rate Switch Settings	3-12
Table 8	Analog Output Connector Pin Assignments	3-15
Table 9	DTM Serial Commands	4-9

1 GENERAL DESCRIPTION

The DTM-151-_S Digital Teslameters offer accurate, high resolution measurement of magnetic flux densities, with direct digital readout in tesla or gauss, and serial communications by fiber optics or RS-232C for system applications. The instruments are light and compact, and the probes are easy to use. The DTM-151 has been engineered to withstand the severe electrical interference produced by high voltage discharge.

This description includes features of the IEEE-488 interface option which is an alternative to the serial communication option. If your teslameter is the IEEE-488 version, refer to the DTM-151-_G User's Manual.

FEATURES

Measures magnetic fields over four ranges up to 3 tesla with polarity indication; resolution up to 1 part in 600,000.

Used with special miniature Hall probe - easy to attach to magnet pole or other hardware. Probe holders are available as optional accessories.

Accuracy and temperature specifications include total system performance, probe and instrument. This is the only meaningful indication of measurement accuracy.

Probe is calibrated, with field and temperature characteristics stored in memory chip contained in cable plug.

Basic accuracy 0.01% of reading + 0.006% of full scale.

Microprocessor reads probe calibration data stored in probe connector and computes corrected field reading.

Temperature coefficient 10ppm/°C overall achieved using temperature sensor in probe. Microprocessor calculates corrected field reading.

Accuracy is verified against nuclear magnetic resonance (NMR) standard.

Probe calibration is verified at many field points, and a printed calibration table is supplied with every probe.

AC mode measures and displays time-varying fields between 8 Hz and 3000 Hz.

Front panel keys set the display to read the desired field range, to read the peak value of the field using the peak hold function, to show the ac field component, and to display the probe temperature.

Peak hold is implemented digitally, has zero sag.

Digital filtering of the displayed field reading suppresses short-term fluctuations. The filtering characteristic is non-linear; small field variations within a narrow window centered on the currently displayed value are filtered; large field changes are displayed immediately. Filter window and time-constant may be changed by remote command. Filtering is controlled by an internal switch.

Two digital communication options: *either* serial (RS-232C and fiber optic)
or IEEE-488 General Purpose Interface Bus.

With the serial option, a single teslameter may be connected to standard RS-232C equipment, or up to 31 units may be interconnected on a Group3 Communication Loop (G3CL) and driven from computer or terminal.

Fiber optic ports duplicate functions of RS-232C signals, for electrical noise immunity and voltage isolation. Fiber optic links may be up to 60 meters in length, using Hewlett-Packard HFBR-3500 series fiber optic cables. Use a Group3 fiber optic repeater to extend communication distance.

The IEEE-488 option fully supports all relevant GPIB functions and commands, including full talker-listener capability, serial and parallel polling, service request, and talker-only.

ASCII control commands are accepted to modify the output data format, to change the rate of data transmission or to request transmission of a single field reading. Other commands set scaling and offset, select the field range, select ac and peak hold functions, turn on and off digital filtering and modify the filter characteristics. System status may be determined remotely.

The system can be operated in triggered mode where field measurements by one or more teslameters are triggered in synchronism with each other by external command.

Internal switches select serial data format and baud rate, device address, string terminators, filtering, field units in gauss or tesla, data format, service request action, EOI action, and perform system reset.

Two analog outputs are available: instantaneous field value (0 to 3 kHz), rectified time-varying (ac) component of field, (8 Hz to 3 kHz).

All model variations are available without display and keys for true 'black box' magnetic-field-to-computer interfacing.

A panel mount model with display is available.

2 SPECIFICATIONS OF DTM-151 SYSTEM

Specifications include LPT-141 or MPT-141 Hall Probe.

Measurements field value and time-varying (ac) component of field

Field ranges 0.3 0.6 1.2 3.0 tesla full-scale,
3 6 12 30 kilogauss full-scale,
with polarity indication
maximum calibration field ± 2.2 tesla, ± 22 kilogauss

Resolution DC mode with digital filtering ON:

1 in 600,000 of bipolar span as shown on front panel display.

range	display resolution		serial/GPIB resolution	
	gauss	tesla	gauss	tesla
0.3 tesla	0.01	0.000001	0.001	0.0000001
0.6 tesla	0.02	0.000002	0.01	0.000001
1.2 tesla	0.04	0.000004	0.01	0.000001
3.0 tesla	0.1	0.00001	0.01	0.000001

Resolution DC mode with digital filtering OFF, and AC mode:

1 in 120,000 of bipolar full-scale span in display:

range	display resolution		serial/GPIB resolution	
	gauss	tesla	gauss	tesla
0.3 tesla	0.05	0.000005	0.001	0.0000001
0.6 tesla	0.1	0.00001	0.01	0.000001
1.2 tesla	0.2	0.00002	0.01	0.000001
3.0 tesla	0.5	0.00005	0.01	0.000001

20-bit digitizing of field reading.

Accuracy DTM-151 with LPT-141 or MPT-141 probe:
 $\pm 0.01\%$ of reading $\pm 0.006\%$ of full-scale max. at 25°C

Temperature Stability DTM-151 with LPT-141 or MPT-141 probe:
calibration: ± 10 ppm of reading/ $^{\circ}\text{C}$ max .
zero drift: $\pm (1 \text{ microtesla} + 0.0003\% \text{ of full-scale})/^{\circ}\text{C}$ max.

add $-3\text{ppm}/^{\circ}\text{C}$ for each meter of probe cable

Time stability $\pm 0.1\%$ max. over 1 year

Measurement rate	10 measurements per second
Response time	Full-scale change of displayed field reading settles to within resolution in less than 0.3 second (filtering off - see below)
Peak hold mode	Displays maximum field since mode entered or reset. Peak hold is implemented digitally with zero sag or decay.
AC mode	Displays time-varying (ac) component of field; frequency response: 8 Hz to 3 kHz at -3dB points. response time-constant: 0.2 seconds. average responding, reads rms value of sinusoidally-varying field. reading is not linearity or temperature corrected.
Display	7-character 7-segment alphanumeric display.
Indicators	8 back-lit legends for: 0.3 0.6 1.2 3.0 tesla range selected, peak hold mode on, digital filtering on, tesla/gauss field units.
Display modes	magnetic field, peak hold field, ac field, peak ac field
Digital filtering	field value filtering smoothes out small fluctuations in the reading; large, rapid field changes are not filtered; internally switch selected.
Keys	2 keys for range selection, access to display modes, zeroing field display, peak hold reset.
Digital interfacing	serial option: RS-232C and fiber optic. parallel option: IEEE-488 General Purpose Interface Bus.
Digital data format	ASCII input commands and output responses.
Commands	requests for field values, setting and inspection of display and control modes, field measurement triggering, entry of numerical values, setting units, output data format, and filter characteristics, test commands.
Output responses	field value in tesla or gauss followed by optional T or G and string terminator(s), system status, numerical data requested by commands, messages.

Serial bit rate	16 rates, switch selected, 50, 110, 134.5, 150, 200, 300, 600, 900, 1050, 1200, 1800, 2000, 2400, 4800, 9600, 19200 baud.
System orientation	Group3 Communication Loop (G3CL) using serial ports, simple loop for 31 devices, no multiplexer required; GPIB with IEEE-488 option.
Fiber optic cable	Hewlett-Packard HFBR-3500, 60 meters max. Fiber optic repeater available for extended communications.
On-board switches	serial baud bit rate selection, load defaults, device address, filtering, string terminators, data format, service request enable, EOI enable.
Analog outputs	dc output - instantaneous field analog: full-scale output: $\pm 3V$ nominal source impedance: 1000Ω accuracy: $\pm 10\%$ bandwidth: 3kHz at -3dB, rolloff 3-pole 60dB/decade ac output - rectified analog of time-varying (ac) field: frequency response: 8Hz to 3kHz at -3dB points time-constant: 0.2 seconds average responding, delivers rms value of sinusoidal field full-scale output: 3V nominal source impedance: 1000Ω accuracy: $\pm 12\%$
IEEE-488 functions	SH1 source handshake capability AH1 acceptor handshake capability T5 talker (basic talker, serial poll, talk-only mode, unaddressed to talk if addressed to listen) TE0 no address extension talker capability L4 listener (basic listener, unaddressed to listen if addressed to talk) LE0 no address extension listener capability SR1 service request capability RL0 no remote local capability PP1 parallel poll capability (configured by controller) DC1 device clear capability DT1 device trigger capability C0 no controller capability
GPIB connector	standard Amphenol 57-20240 with metric standoffs

Memory back-up	user-entered data storage for 30 days with power off.
Power source	ac: min 8V at 0.7Arms, max 15V at 0.4Arms dc: min 9V at 0.5A, max 19V at 0.25A ac line input plugpack supplied. Power fuse on processor board: 1 amp antisurge 5 x 20mm To obtain maximum spark protection, use PS12D7 power supply and ferrite kit 11000036. See section 3.12. L option: 115/208/230 V ac power input.
Enclosure	aluminium, 217 x 125 x 50 mm, textured finish, light tan colour, tilt stand fitted to bench models.
Ambient field	Maximum operating field for instrument: 10 millitesla with single-range probe, 0.5 millitesla with multi-range probe.
Temperature range	0 to 50°C operating, absolute maximum temperature of probe 60°C.
Instrument weight	1.2 kg, shipping weight 2.5 kg.
Probes	LPT series, transverse types, sensitive area 4 x 1.6mm, probe head size: LPT-141 and LPT-231: 14 x 14 x 2.5 mm MPT series, miniature transverse types, sensitive area 1.0 x 0.5mm, probe head size: MPT-132 MPT-230 MPT-141 MPT-231: 14 x 5 x 2 mm Standard cable length: 2 meters. Special cable lengths to 30 meters. Probe cable is shielded.

ORDER CODES

Basic teslameters,
capable of four measurement ranges 0.3, 0.6, 1.2, 3.0 tesla full scale,
support all LPT and MPT series probes, plugpack supplied except for option -L.

DTM-151 (supports LPT-141, LPT-231, MPT-141, MPT-231 probes)

Options

Bench style instrument with display: add suffix **-D** |
Panel-mount version: add suffix **-P** | one of these options
Without display, plugpack powered: add suffix **-N** | must be specified
Without display, line voltage power: add suffix **-L** |
Serial data input/output, RS-232C & fiber optic: add suffix **S** | must select
IEEE-488 GPIB capability: add suffix **G** | one option

Example: DTM-151-DS

Probes

Four ranges, standard 2 meter shielded cable

LPT-141-2s | standard sensitivity **LPT-231-2s** | high sensitivity
MPT-141-2s | probes **MPT-231-2s** | probes

Single range probes: add range suffix -03, -06, -12, -30.
Special probe cable lengths: change length suffix to -Xs,
where X is the desired cable length in meters, 30 max.

Example: LPT-141-10s for 10 meter cable

Accessories

fiber optic cable fitted with connectors, 60 meter length maximum.
probe holders.
fiber optic repeater, bidirectional, model **FOR-2PP**.
fiber optic to RS-232C adaptor, model **FTR**.
digital display for remote control & readout of field values, model **DPM**.
rack panels, 3.5 inches high (2U), for rack mounting 1, 2, or 3 DTMs or DPMs.
ferrite kit 11000036 for spark protection.
power supply PS12D7 for spark protection.

3 SETTING UP

3.1 INTRODUCTION

This manual provides operating instructions for all members of the DTM-151 family of digital teslameters with serial communications, and their companion LPT-141, LPT-231, MPT-141, and MPT-231 series Hall probes. For a summary of all current members of the product family, see page 2-5. These instructions are written for a teslameter with front panel display and keys, DTM-151-DS/PS. Users of teslameters without display and keys should ignore sections of this manual referring to these features. All other aspects of operation are identical. Before using your teslameter for the first time, please read through sections 3.2, 3.3, 4.1, 4.2, and 4.3 of this manual. This will give a quick introduction to basic operation of the instrument. If you have a teslameter without display, DTM-151-NS/LS, also read sections 3.4, 3.5, 3.6, 3.7, and 4.5. If you have the panel-mount version, DTM-151-PS, mounting instructions are to be found in section 3.11. For help regarding operation in electrically noisy areas, see section 3.12.

3.2 CONNECTING THE HALL PROBE

Before handling the probe, please read the following.

Group3 Hall probes are built to be as robust as possible for a small, precision device. However, it is most important that certain precautions be taken when handling and installing probes so that they are not damaged or destroyed, and to preserve their accurate calibration.

Mount the probe head so there is no pressure which will tend to bend or depress its ceramic rear surface. If the probe head is clamped, make sure the surface in contact with the ceramic is flat and covers the whole of the ceramic surface. Do not apply more force than is required to hold the probe in place. Any strain on the ceramic will alter the probe's calibration, and excessive force will destroy the Hall element inside.

When the probe head is mounted, the cable should be clamped firmly nearby so it cannot be torn away from the probe head if accidentally pulled. The flexible section adjacent to the probe head can be carefully folded to allow the cable to come away in any direction, but avoid repeated flexing of this section.

Keep the cable out of the way of foot traffic. Do not pinch the cable, or drop sharp or heavy objects on it. A severed cable cannot be re-joined without altering the probe's performance, and requires factory repair and re-calibration.

Your DTM must be used with a Group3 Hall probe. The probe may be one supplied with your teslameter, or it may have been obtained separately. In any case, calibration is preserved when probes are exchanged between instruments. In order to obtain specified performance, the DTM-151 should be used only with a -141 and -231 series probes.

The standard probe cable length is 2 meters. Probes with non-standard cable lengths up to 30 meters may be ordered from your Group3 supplier. The cable used for Group3 probes is shielded to reduce pickup of induced noise from external sources. Such noise may reduce the accuracy of the instrument, cause malfunctioning, or in extreme circumstances even result in damage to the internal circuitry. See section 3.12.

With the DTM unpowered, plug the probe connector into the instrument. The pin side of the plug is inserted into the large opening in the rear of the DTM, with the plug's label uppermost when the instrument is standing right way up. It is easy to find the correct mating position for the plug, and then push it fully home, but if any difficulty is experienced at first, remove the DTM's top cover by loosening the central screw and lifting the cover off. Now it is possible to see when the plug is centrally located and its overhang slides over the card-edge receptacle, ensuring that its pins engage correctly. Tighten the connector retaining screws finger tight. Do not leave these screws loose as they form part of the shielding system around the teslameter. The teslameter should always be used with both covers attached.

Always disconnect power from the teslameter before connecting or disconnecting the probe. If the probe connector is inserted or withdrawn with power on, data stored in memory may be corrupted, leading to erroneous field readings. If this happens, the defaults switch S2-8 should be switched ON then OFF while power is applied. See Fig. 5 and Table 4.

When no probe is connected to the DTM, the display reads **noProbE**.

3.3 CONNECTING THE POWER SOURCE

All teslameter versions, except for the L option, are supplied with a plug-pack. Connect the plug-pack to a convenient ac power source, first checking the voltage marked on the plug-pack, and insert the cable connector into the power receptacle on the DTM rear panel.

Instead of the plug-pack, the unit can be powered by any convenient source of ac or dc (either polarity), 9 to 15 volts, capable of supplying 0.7A rms ac or 0.5A dc. The cable connector required for power connection to the DTM is a standard coaxial plugpack connector with 2.1mm centre hole and is generally available from electronics suppliers.

For extra immunity to damage and operational disturbance caused by serious high voltage sparking near the teslameter, the use of the Group3 model PS12D7 off-line switch-mode power supply and the Group3 ferrite kit part no. 11000036 is recommended. These accessories will greatly reduce the amount of electrical transient energy entering the teslameter. The ferrite kit includes a suppressor which fits to the probe cable near the point of entry to the teslameter to reduce the effects of transients picked up on the probe cable. For a full discussion of techniques to promote trouble free operation in electrically noisy environments, see section 3.12 of this manual.

Powering the L option teslameter -

The L option will accept power input from the ac power line.

Access to the power input terminals of the L option is obtained by taking off the orange cover; remove the 3 fixing screws to release the cover.

Use 3-conductor power cord. For safety from electrical shock it is essential to provide a reliable ground connection to the DTM case. Make sure the ground wire is connected as shown in Fig. 1. Strip about 60 mm (2.5 in) of outer jacket from the cord, and strip 5 mm (3/16 inch) of insulation from the 3 wires. Pass the cord through the grommetted hole in the cover. Loosen the screw securing the cable clamp and pass the cord through the clamp. Tighten the clamp on the outer jacket. Terminate the wires and fit links according to the supply voltage as set out in Fig. 1 below. Replace the orange cover, making sure that wires are not pinched in the process. For safety reasons, do not operate the unit with the cover off.

Note that input power protection is provided by a thermal fuse wound into the power transformer. This fuse will open in the event of transformer overheating rather than on excess current. The power input must be connected as shown to include the thermal fuse in the circuit correctly. If a fault causes transformer overheating and subsequently the fuse opens, the transformer must be replaced with the genuine Group3 part.

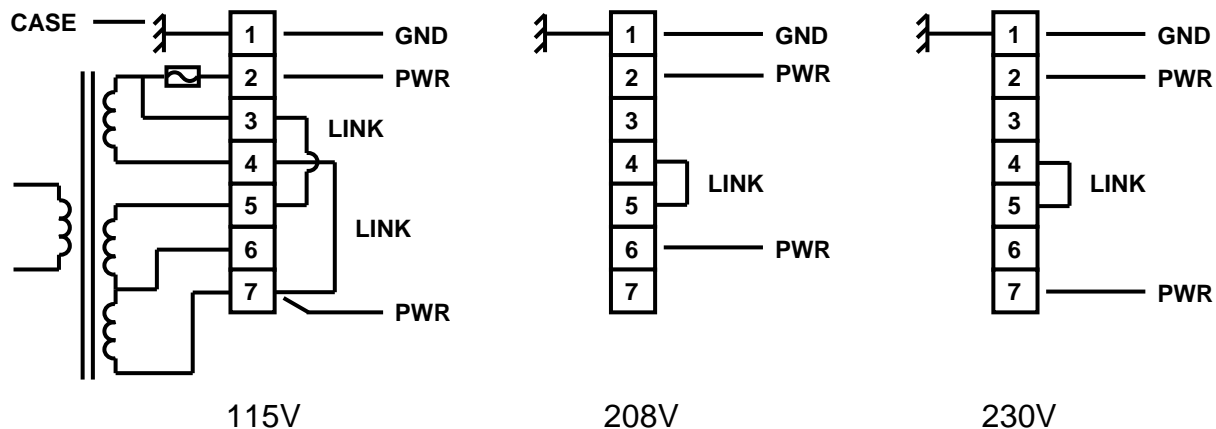

Fig. 1. Power Input Connections of the -L option

If desired, the wiring may be protected by installing an external fuse in the ac power feed. Suggested fuse ratings are 200 mA for 115 volts, or 100 mA for 208 and 230 volt operation.

When the unit is first powered up, the display shows **Group3** for 2 seconds before field measurements appear. If the Hall probe is not plugged in, the field reading display is replaced with **noProbE**.

3.4 FIBER OPTIC CONNECTIONS

The DTM-151-_S has facilities for communicating with external devices, such as computers or terminals, using its serial I/O ports. The teslameter may also be set up to relay communications through other compatible Group3 devices, using the Group3 Communication Loop. See section 4.5.

There are 3 bi-directional ports, 2 using standard RS-232C signals, the third employing fiber optics. In electrically noisy environments, or where ground loops could be troublesome, or if a voltage gradient must be traversed, it is advisable to use fiber optics for the serial data link. The teslameter's fiber optic ports accept Hewlett-Packard HFBR-3500 series fiber optic cables up to 60 meters in length.

Fiber optic cables are fitted with a blue connector one end and a grey connector at the other. Although functionally identical, the colours make it easier to keep track of cable routing when connecting up a system. The convention is to use grey at send ports and blue at receive ports. To connect the cables, simply push the connector in through the appropriately labelled hole in the teslameter's rear panel. The connector will snap into place. To disconnect, give the cable a gentle tug. Inspect the cable ends to ensure the inner core has not retracted. Loose cable ends should be protected from dirt and scratching.

3.5 ELECTRICAL SERIAL DATA INPUT/OUTPUT CONNECTIONS

Serial data connections to the teslameter can be made electrically in two ways, as alternatives to the fiber optic method described in the previous section:

3.5.1 The G3CL Ports

The two 4-way Group3 Communication Loop connectors, one each for send and receive, provide an electrical alternative to the fiber optic ports, and handle the same data. Signal levels are equivalent to RS-232C levels. RS-232C handshake signals are not present at these ports.

The G3CL ports allow serial connections to be made using a simple twisted pair or coaxial cable for each data direction, and avoid consideration of handshake signals if these are not required in the application.

Connection to the G3CL ports requires two Molex receptacles type M5051-4 with M2759 crimp terminals. Pin assignments are given in Table 1 below. The RS-232C standard allows cable lengths of up to 50 ft, but in practice longer cables will work reliably, particularly at the lower bit rates. Connection is made through the labelled opening in the teslameter's rear panel.

In the device at the send port, pin 2 (common) is connected to circuit common. However, at the receive port the signal drives an optical coupler without any direct connection to the circuitry. This arrangement avoids ground loops which can inject noise into the link and give rise to transmission errors.

pin	use
1	signal active
2	signal common
3	cable shield (optional)
4	not used

Table 1. G3CL Connector Pin Assignments

3.5.2 The RS-232C Connector

The RS-232C connector is a 26-pin field which can be used to connect the teslameter to a computer, terminal, printer, or other external equipment which can send and receive RS-232C signals. The pin field will connect with a standard 26-way flat cable socket connector, for example 3M type 3399-6000. The pin assignments follow those of the standard 25-way RS-232C connector, starting at pin 1 and omitting pin 26. If desired, an adaptor cable may be used to allow cables with 25D connectors to be plugged in to the teslameter.

In order to avoid the conflicts and confusion which often arise when RS-232C is used to interconnect equipment which cannot be classified strictly as either communications or terminal equipment, the DTM has been provided with a number of user options in the form of moveable jumpers and wire-wrap posts on the Processor Board. Thus pins 2 and 3 may be connected to send and receive signals, respectively, or vice versa.

Similarly, a number of the most-used RS-232C handshake signals are provided on the board, and these may be routed to appropriate pins on the connector if desired. But their use is optional. In most cases no active handshaking need be used. Some external equipment may require certain signal lines to be held high for correct operation. These options are provided for (see below).

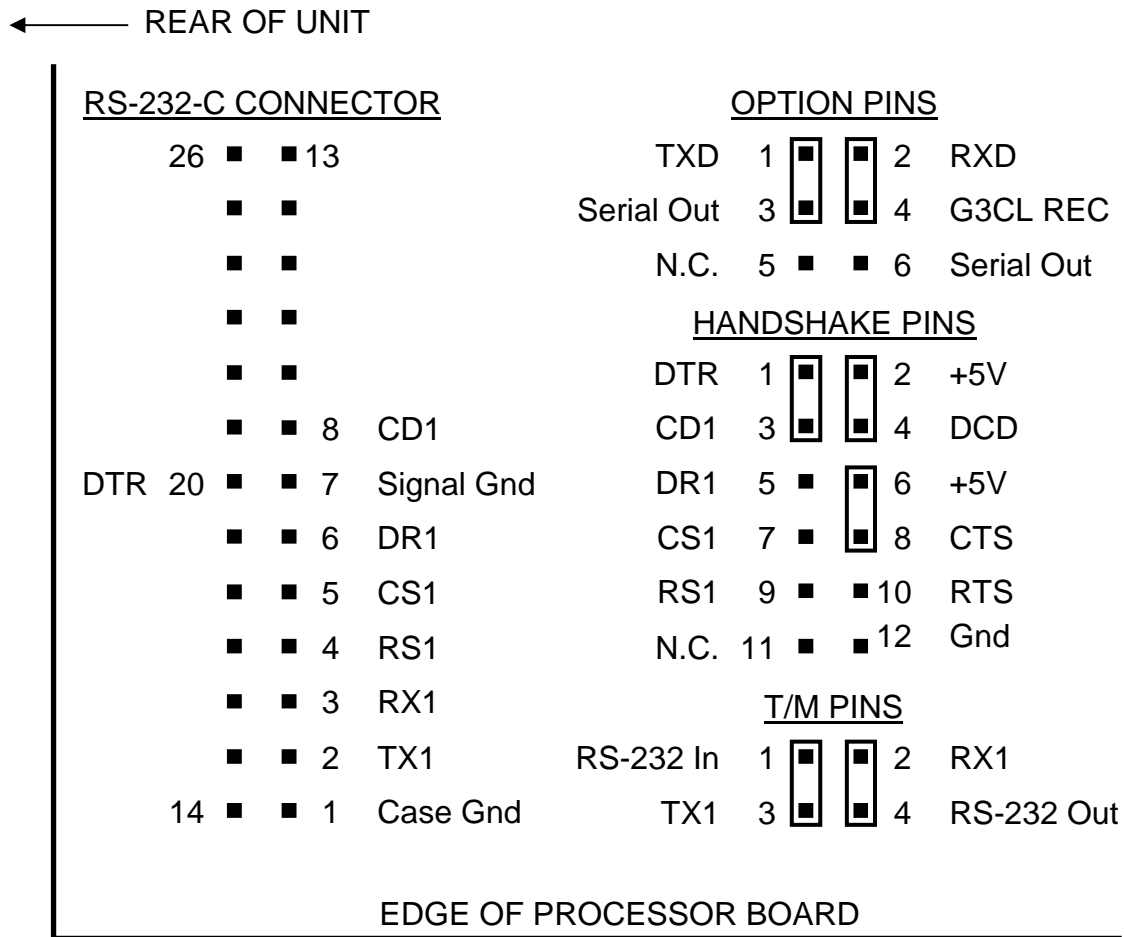

Fig. 2. RS-232C Connector and Jumper Locations

The DTM can provide one output handshake signal, RTS, which is asserted high when the unit has data it wishes to transmit.

The DTM can also accept up to two input handshake signals, CTS and DCD. If CTS is held low by the external equipment, then no data will be transmitted. When low, DCD inhibits and initializes the receive input of the teslameter. DCD must be high to allow the unit to accept incoming data. If these inputs are not connected to the RS-232C pin field, the relevant pins must be tied to +5 volts on the Processor Board, using the jumpers provided.

The handshake signals can be used only when the teslameter is connected directly through its RS-232C connector to an RS-232C compatible device. When several Group3 devices are arranged in a loop using the Group3 Communication Loop ports, RS-232C handshaking cannot be used. CTS and DCD must be tied high in this case.

Table 2 below gives the pin assignments and signal names when the teslameter is configured as a Data Terminal Equipment (DTE). This will be referred to as terminal mode.

The unit can also be set up to behave like a Data Communications Equipment (DCE), for example a modem. The instrument is then said to be in modem mode. See the RS-232C connector pin assignments for modem mode below in Table 3. Fig. 2 shows the location of the RS-232C pin field, moveable jumpers and wire-wrap posts on the Processor Board.

For terminal mode, the send and receive (T/M) jumpers should be pushed onto the square posts lined up parallel with the long side of the circuit board. In modem mode, the jumpers are set at right-angles to the above. See Fig. 3.

pin	RS-232C signal name	signal direction	connection in DTM
1	protective ground		instrument case
2	transmit data	output	TX
3	receive data	input	RX
4	request to send	output	*RTS or +5V
5	clear to send	input	*CTS or open
6	data set ready	input	*DCD or open
7	common		circuit common
8	carrier detect	input	*DCD or open
20	data terminal ready	output	*+5V

* option according to requirements of external equipment.

Note: connect CTS and DCD to +5 volts if not otherwise used.

Table 2. RS-232C Connector Pin Assignments, Terminal Mode

pin	RS-232C signal name	signal direction	connection in DTM
1	protective ground		instrument case
2	transmit data	input	RX
3	receive data	output	TX
4	request to send	input	*DCD or open
5	clear to send	output	*+5v or pin 4
6	data set ready	output	*RTS or +5V
7	common		circuit common
8	carrier detect	output	*RTS or +5V
20	data terminal ready	input	*CTS or open

* option according to requirements of external equipment.

Note: connect CTS and DCD to +5 volts if not otherwise used.

Table 3. RS-232C Connector Pin Assignments, Modem Mode

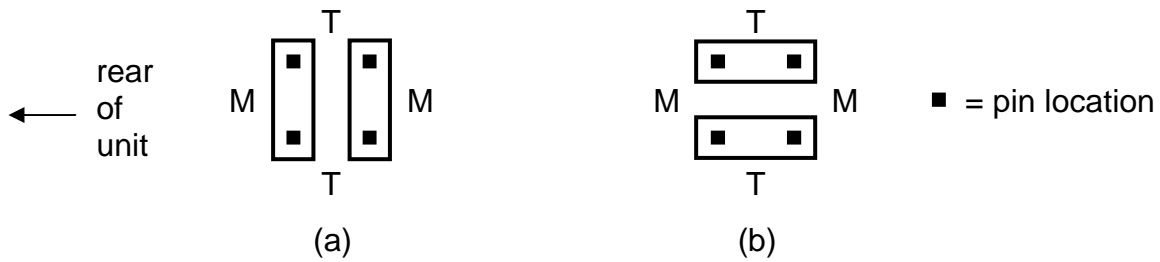

Fig. 3. Send and Receive Jumpers (a) Modem Mode, (b) Terminal Mode

The option 1 and 2 jumpers configure the relationship between the RS-232C connector and the G3CL ports. For single device systems, option 2 should be selected. Refer to Fig. 4 below. Section 4.5 describes the use of the option jumpers in setting up the alternative G3CL arrangements.

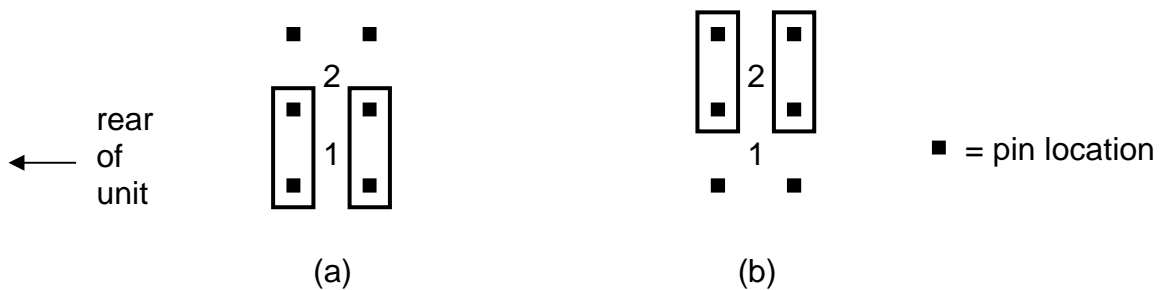

Fig. 4. Option Jumpers (a) Option 1 (b) Option 2

Fig. 2 also indicates the positions of the wire-wrap posts on which appear the RTS, CTS, and DCD signals, +5 volts and ground, and posts which connect to RS-232C connector pins 4, 5, 6, 8, and 20. These pins may be wire-wrapped according to the options set out in Tables 2 and 3. When pins are adjacent they may be connected more easily with push-on jumpers.

3.6 INTERNAL DIP SWITCH SETTINGS

The Processor Board in the DTM is provided with two sets of DIP switches, allowing the user to set up teslameter operation and communications according to system requirements.

To obtain access to the switches, turn the DTM over and take off the bottom cover by loosening the single central screw. Refer to Fig. 5 for switch locations.

Switch functions are as follows:

- S1 8-way DIP switch - sets device address; sets serial data format:
number of data bits, parity, and number of stop bits.

- S2 8-way DIP switch - selects operation mode and communication mode.

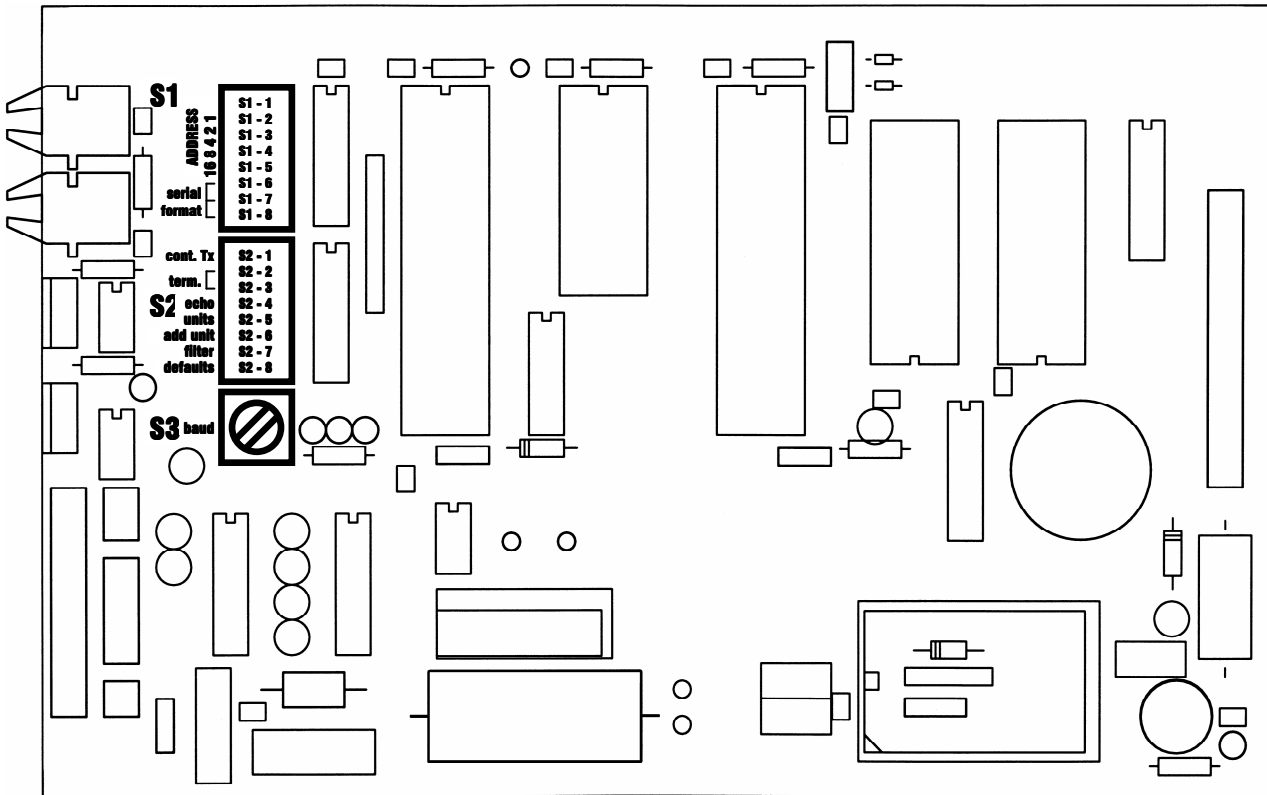

Fig. 5. Location of Processor Board Switches

Detailed DIP switch settings are given in Tables 4 and 5 below.

switch	function	switch OFF	switch ON
S1-1	set device address	* adds 0 to address	adds 1 to address
S1-2	set device address	* adds 0 to address	adds 2 to address
S1-3	set device address	* adds 0 to address	adds 4 to address
S1-4	set device address	* adds 0 to address	adds 8 to address
S1-5	set device address	* adds 0 to address	adds 16 to address
S1-6)	*	maximum valid address = 30
S1-7)serial data format	* see Table 5 for encoding format	
S1-8)	*	
S2-1	transmission mode	on demand only	* every reading sent
S2-2	select terminator	line feed	* carriage return
S2-3	double terminator	* disabled	enabled
S2-4	echo commands	* echo OFF	echo ON
S2-5	field units	* tesla	gauss
S2-6	units symbol	no symbol	* symbol after data
S2-7	digital filtering	filtering OFF	* filtering ON
S2-8	defaults	* no action	defaults loaded
			* factory setting

Table 4. DIP Switch Functions

The switches are read by the processor once per second, so the effects of changed settings can be observed in real time.

S1-1 through S1-5 set the DTM address. If the system contains only one device, it is recommended that its address be set to 0 (S1-1 through S1-5 OFF). Then the external control device does not need to initiate commands with a device-address command.

S1-6, 7 & 8 configure the serial data format:

S1-8	S1-7	S1-6	data bits	parity	stop bits
* OFF	* OFF	* OFF	7	even	2
OFF	OFF	ON	7	odd	2
OFF	ON	OFF	7	even	1
OFF	ON	ON	7	odd	1
ON	OFF	OFF	8	none	2
ON	OFF	ON	8	none	1
ON	ON	OFF	8	even	1
ON	ON	ON	8	odd	1

Table 5. Serial Data Format Switch Settings

S2-1, in a single device system, can be set ON so the DTM will transmit field readings continuously at the maximum rate of 10 per second without first being addressed.

S2-2 selects the character sent as string terminator. With the switch OFF, the terminator is the line feed character. When the switch is ON, carriage return is used.

S2-3 when ON introduces a pre-terminator character before the final string terminator selected by S2-2. The pre-terminator is the character not selected by S2-2. The terminator sequence as selected by S2-2,3 is as follows:

		S2-2	
		OFF	ON
S2-3	OFF	lf	cr
	ON	cr, lf	lf, cr

Table 6. String Terminator Switch Settings

S2-4 controls the echoing of input commands by the teslameter. If echoing is selected, every command from the external control device is echoed before the response to the command is transmitted. Usually echo is set ON if the 26-way RS-232C port is used, and OFF when using either pair of G3CL ports. If echo is ON in the latter case, the teslameter will transmit each input command twice, first the original command rippling through, then the echoed command. When echo is OFF when the RS-232C port is used, the input command will not be returned to the external control device.

S2-5 selects the field units used by the DTM: OFF for tesla, ON for gauss.

S2-6 when ON adds the field and temperature units characters T or G and C to the transmitted string after the numerical values.

S2-7 enables digital filtering of the field value when switched ON.

S2-8 allows the user to reload default settings, where all the numerical values entered by the operator are returned to their default values, and switch selectable functions are instated as set on the switches. To load defaults, switch S2-8 ON, wait 1 second, then switch OFF again. If the switch is left ON, defaults will be loaded each time the teslameter is powered up. The display shows the message **rESEt** each time defaults are loaded. When defaults are loaded on power up, the **rESEt** message follows the Group3 power up message.

The functions controlled by S2-1 through S2-7 can also be changed remotely by serial input commands as set out in section 4.5.2. To revert to switch control, change the switch setting, wait 1 second, then switch to the desired position.

3.7 BIT RATE SELECTION

A 16-position switch is provided on the Processor Board for setting the serial data bit rate (baud). See Table 6 for switch position versus bit rate, and Fig. 5 for the location of the switch. The baud rate must be set to match that of the communicating device.

switch position	baud bits/sec	
0	50	
1	110	
2	134.5	
3	150	
4	200	
5	300	
6	600	
7	900	
8	1050	
9	1200	
A	1800	
B	2000	
C	2400	
D	4800	
E	9600	Preferred
F	19200	

Table 7. Bit Rate Switch Settings

3.8 SECOND WATCHDOG OPERATION

The teslameter's microprocessor circuitry includes two watchdog timers. The first watchdog continually monitors the operation of the microprocessor. If for any reason, such as a severe burst of transients occurring near the instrument, the microprocessor stops running or enters an invalid mode of operation, the watchdog will automatically reset the microprocessor and restart the operating program. At most the user may observe a 1 to 2 second pause.

In very rare circumstances, again caused by a particularly severe transient, the processor could enter a mode of operation that fools the watchdog into believing that all was well, whereas in fact the microprocessor could be running an endless loop doing nothing useful. To cope with these circumstances, a second watchdog is included in the circuitry. The second watchdog can be set to operate in one of two modes, or it can be disabled, as determined by the setting of a jumper on the processor board. See Fig. 6.

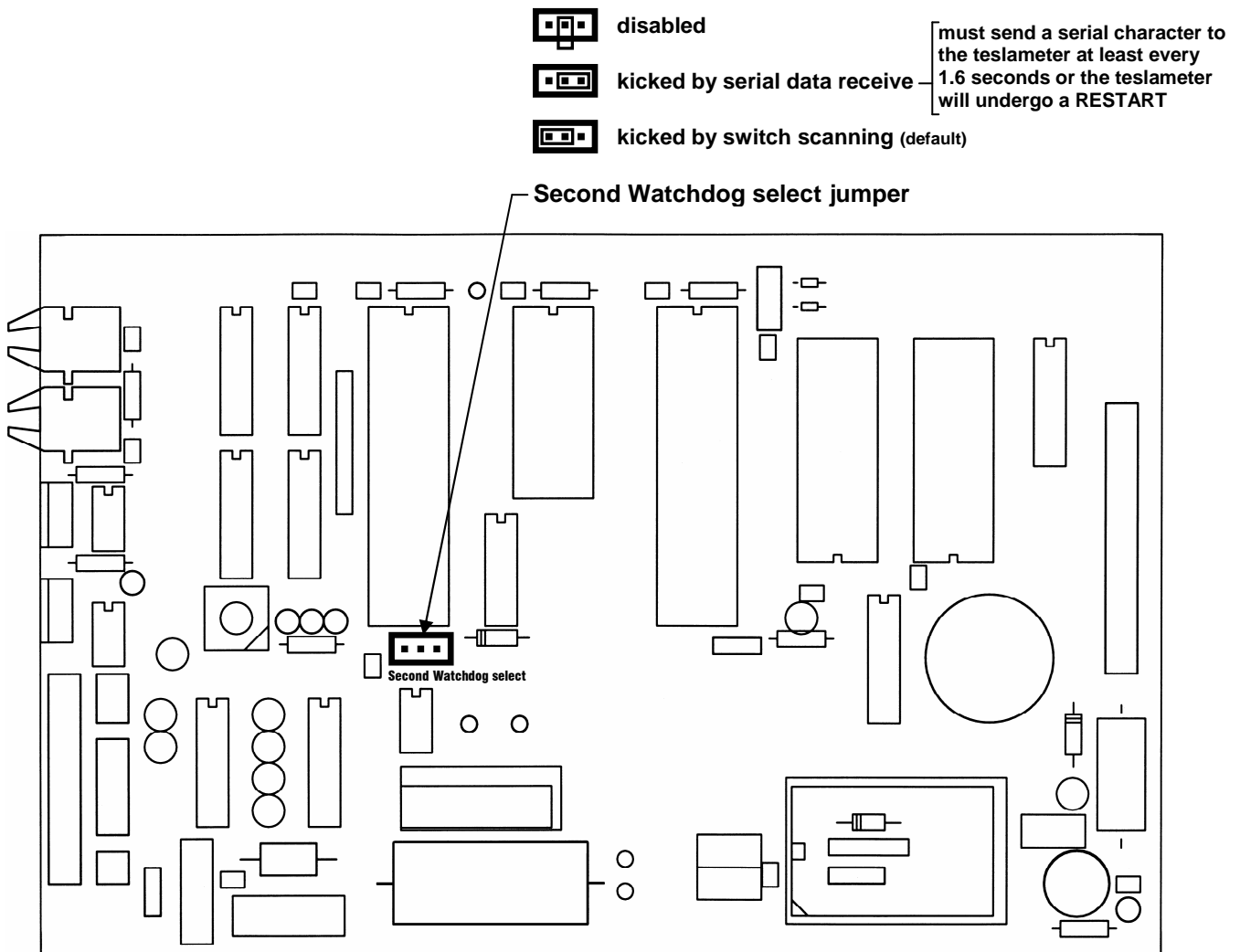

Fig. 6. Location of Second Watchdog Select Jumper

Mode 1 (default) senses a 1 second pulse from the switch scanning circuit. This mode adds to the effectiveness of the first watchdog, and like the first watchdog its operation is automatic and needs no operator intervention.

Mode 2 senses the received serial data. If this mode is selected the teslameter cannot be used as a stand-alone bench instrument. It is necessary for the teslameter to be in continuous communication with an external control computer. The computer can force a hardware reset by withholding communications for more than 1.6 seconds. To maintain continuous normal teslameter operation, the computer must send at least 1 character every 1.6 seconds or less. If the computer determines that the teslameter is not responding to commands or is sending erroneous data, it can reset the teslameter as described above.

Once normal operation has been restored, it is sometimes useful for the computer to issue the CTRL X command to reload default numerical values and switch settings, thus correcting data that may have been corrupted by the disturbance.

It is suggested that in extreme spark conditions that switch S2-8 (defaults) be left ON so that defaults are restored on power up, hardware reset, and CTRL U command.

3.9 ANALOG OUTPUTS

3.9.1 Connectors

Two output signals are available at the rear of the teslameter. These signals are referred to as the dc and ac outputs, and are described below. The analog outputs are not corrected for linearity or temperature errors. The cable connector required is a Molex receptacle type M5051-4 fitted with M2759 terminals. It carries both outputs. Pin assignments are given below.

pin	signal
1	ground
2	ac output
3	ground
4	dc output

Table 8. Analog Output Connector Pin Assignments

3.9.2 DC Output

The dc output is the Hall probe signal amplified to 3 volts full-scale, and gives an indication of the instantaneous field value from dc to 3kHz (-3dB), with a roll-off of 60dB/decade. Field direction is indicated by the output voltage polarity. There is a small zero offset arising from the probe zero-field output and amplifier offsets. The output impedance is 1000 ohm with a 10nF capacitor to common for noise filtering.

3.9.3 AC Output

The ac output is a positive voltage analog of the time-varying or ac field component. To generate this output the instrument removes the dc component of the analog output described above, then full-wave rectifies any remaining ac component. The overall response to varying fields is 8Hz to 3kHz, and the rectified output has a time constant of 0.2 seconds. The rectifier circuit responds to the average value of the ac waveform, but is calibrated such that if the waveform is sinusoidal, the reading corresponds to its rms value. The output impedance is the same as for the dc output.

3.10 GROUNDING

All parts of the teslameter's metal case are connected together to form an integral electric shield around the circuitry inside. When the probe connector is plugged into the teslameter and the retaining screws are tightened, the probe connector case and the teslameter case are connected together and form an integral shield around the circuitry inside. The cable shield is added to the case shield and extends protection from electrical interference almost up to the probe head.

Because there is an internal connection between teslameter circuit common and the probe connector case, when the probe connector is engaged and the retaining screws tightened the teslameter circuit common will be connected to the case. Do not make an additional connection between circuit common and the case at any point, including at the RS-232C connector or at the G3CL connectors on serial teslameters, or at the GPIB connector on teslameters with the IEEE-488 option. Such additional connection will form a ground loop and may introduce errors in the measured field value.

The shielding provided with the above arrangement should be sufficient protection against EMI in most cases, especially when the probe cable is shielded. Sometimes it may be found helpful to ground the teslameter case to a good electrical ground point. Connection can be made to the case by inserting an appropriate lug or terminal under the head of one of the rear panel fixing screws.

Further protection from transient interference can be obtained by using model PS12D7 power supply in place of the usual plugpack supplied with the teslameter, and by installing the Group3 ferrite kit part no. 11000036. See section 3.12 of this manual.

For electrical safety, the case of the L version must be grounded through the third wire of the power input cord.

3.11 INSTALLING THE PANEL MOUNT OPTION

Model DTM-151-PS is supplied fitted with a special front bezel which has threaded studs to allow panel mounting. A panel mount support bracket (part 17000058) is included to help support the teslameter. Group3 can supply 19-inch wide, 2U (3.5") high rack panels to hold one, two, or three teslameters (parts 17000025, 17000026, and 17000027, respectively). Alternatively, the user can mount the teslameter in any panel of thickness up to 3/16" (4.76mm). Dimensions for the cutout and drilled holes are shown below in Fig. 7.

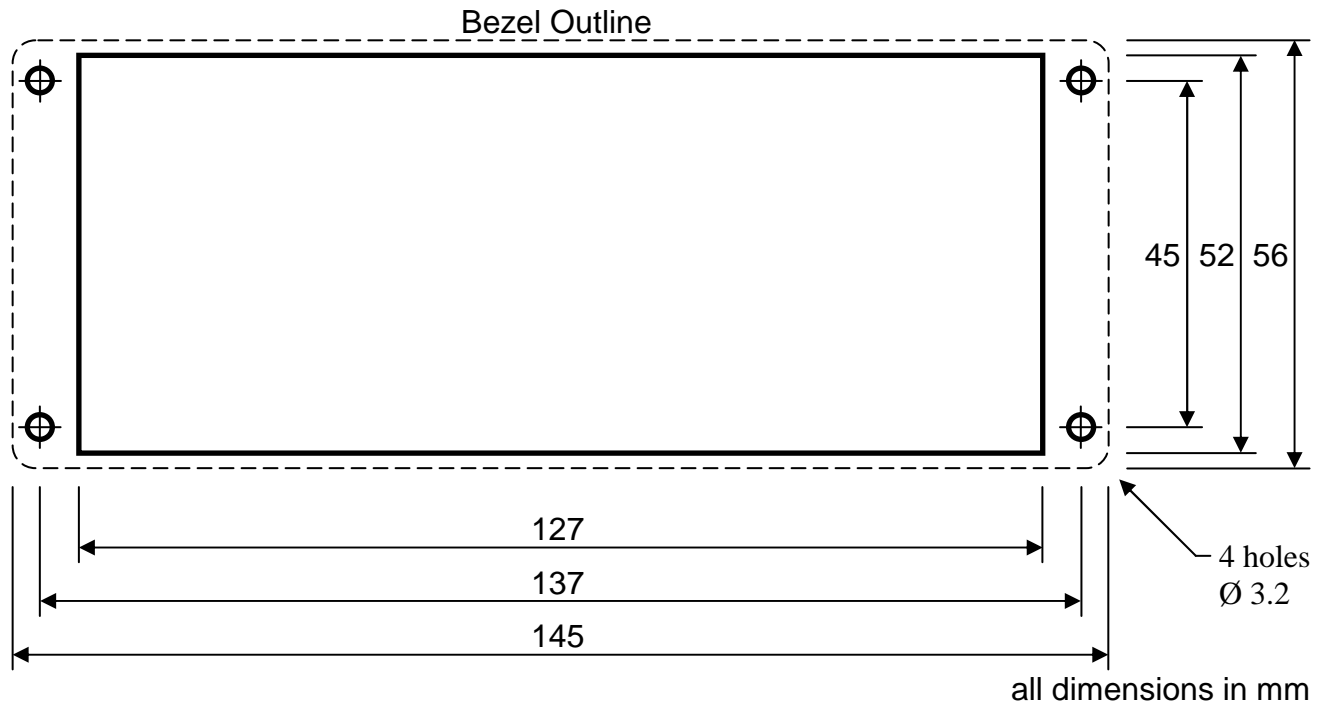

Fig. 7. Panel Cutout Dimensions

To fit the teslameter to the panel, first remove the nuts and washers from the bezel studs. Push the teslameter through the panel from the front, making sure all the studs fit through the small holes. While holding the teslameter in place, place the support bracket under the teslameter from the rear, pushing it up to the panel with the studs through the holes in the bracket. Put the flat washers on the studs, then the lock-washers, and finally screw on the nuts. Make sure the teslameter is resting on the bracket, then tighten the nuts, preferably using a long-stemmed nut driver.

3.12 INSTALLATION TECHNIQUES FOR ELECTRICALLY NOISY ENVIRONMENTS

The DTM-151 is a precision electronic measuring device. Because of the nature of the measurements it is asked to do, it is frequently exposed to conditions that are considerably worse than are normally encountered by precision instruments. Therefore, the teslameter has been carefully engineered to be as immune as possible to sparks and other forms of interference through the use of several kinds of power input filtering and a special high-isolation switchmode power module built into its circuitry. The design has been verified by extensive testing, using high energy sparking in close proximity to both the teslameter instrument case and the probe. Nevertheless, due care should always be taken when installing the teslameter system.

The teslameter and its probe must be protected from any chance of receiving a direct hit by a high voltage discharge. The probe should have shielded cable if the meter is to be used in an electrically noisy environment. The cable shield is an RFI screen, not a high current path, so if there is any possibility of an arcing discharge hitting the probe area, then the probe head and part or all of the cable must be enclosed in a metal tube (non-magnetic near the probe head), or shielded in some other way.

The probe cable should be routed away from any power, high current or high voltage wiring. It should be shielded from any capacitively coupled noise effects. If the cable runs close to any section of the apparatus that could be subjected to a very rapid change of potential when a spark discharge occurs, then the probe cable may need additional shielding to prevent capacitive coupling of the noise.

The retaining jack screws designed to hold the probe connector onto the teslameter must be screwed up finger tight, as they form part of the electrical connection of the shield system. The woven braid of the probe cable is terminated to the probe connector case. The retaining screws then connect the probe connector case to the teslameter case.

The teslameter itself should be sited in a sheltered location, where it will not be exposed to spark discharges or radiated or capacitively coupled noise. The teslameter case is made of metal for shielding reasons. However, of necessity it is less than perfect, as apertures have to be left in the case for the display and various connectors etc. The unit is a precision measuring device, and should be treated with care, not subjected to adverse environmental conditions.

The plugpacks supplied with each teslameter should be plugged in to a clean mains power supply. Noise on the mains will work its way through the transformers and disturb the teslameter. Simple mains filters are readily available if there is only one mains supply for the whole machine. Route the low voltage lead away from high current or high voltage wiring. Ideally cut the low voltage lead to the minimum length required for the installation, and re-connect the plug to it.

If you are using the serial communication features of the teslameter, take advantage of the noise immunity of the fiber optic facilities available, rather than using the wired RS-232C connection. Fiber optics were included in the DTM-151 for the express purpose of providing noise free communication in hostile applications. The fiber optic cables used with the DTM-151 are economical and convenient to use - simpler in fact than wiring. To interface the fiber optic cables to your computer or other data acquisition system, use a Group3 model FTR fiber optic adaptor.

See section 3.8 for a description of the second watchdog operation.

Grounding the teslameter case.

The probe shield is terminated to the probe connector case, which is then connected by the retaining screws to the teslameter chassis. At this point the entire shield system is floating. In some installations it is beneficial to have the system floating, but most frequently it is sensible to have the shields grounded.

If the teslameter is panel mounted, then the case is almost certainly electrically connected to the control rack, and grounded that way. However if the teslameter is a bench unit, then the rubber and plastic feet on it will isolate the case. If the case does need to be grounded then loosen one of the screws on the back panel and put a grounding lug under the head of the screw. It is most convenient to use a 1/4inch (6.35mm) quick connect tab. The grounding wire can then be easily disconnected if the teslameter has to be moved. Use a heavy gauge, short wire to ground the unit to a substantial grounding point nearby. If the teslameter is sitting on metalwork, then it should really be grounded to that metalwork so it is at the same potential.

Further Preventative Measures.

If problems are still encountered, despite following the precautions detailed above, then there are some further things to try.

Tests have shown that, in an electrically noisy environment, the main path of noise entry to the teslameter is through the low voltage power supply input. The trouble could come from mains borne transients working their way through the plugpack transformer, or from interference picked up on the low voltage lead itself. The quickest and simplest fix for this problem is to wind the power lead several times through a ferrite core. Use a thick walled ferrite tube of substantial size - a simple small torroid is not nearly as effective. A suggested ferrite is the TDK part number HF70RH26x29x13. This is a tubular ferrite, 29 mm long, 26mm outside diameter, and 13mm inside diameter. Winding the power lead four times through this core, really close to the teslameter, significantly reduces noise upsets.

If the analog outputs are wired up, then shielded twisted pair should be used for all wiring, routed away from any high current or high voltage cabling. In a really noisy environment it can be beneficial to put this analog cabling through a ferrite tube for a few turns to suppress induced noise.

The probe cable itself can be passed through a ferrite core. The internal diameter will need to be sufficient to pass the probe head through. An MPT (miniature) probe head is nearly the same size as shielded cable (6.5mm diameter), but an LPT probe head needs an internal ferrite diameter of 14mm or more. Alternatively a split core ferrite variety can be used, such as TDK part HF70RU16x28x9. The core should be placed where the probe cable enters the probe connector, and optionally a second ferrite can be placed where the cable shield layer ends, approximately 300mm back from the probe head.

Group3 can supply an alternative power supply to be used instead of the usual plugpack. The alternative power supply is model PS12D7. It is a universal voltage (85 - 270V 50/60Hz) input, 12Vdc 7W output unit with excellent input-output isolation for noise and transients. The PS12D7 is DIN rail mounted. In conjunction with the PS12D7 we recommend the use of our ferrite kit, part no. 11000036, which implements the ferrite filtering measures described above. The kit consists of a 1.2 meter length of twin cord with a ferrite tube fitted. This cord is intended to connect between the PS12D7 and the teslameter. The kit also contains a split ferrite tube and housing for fitting to the probe cable.

4 OPERATING INSTRUCTIONS

4.1 ZEROING

The DTM-151 digital teslameter has a very stable zero field reading. Nevertheless, it is good practice to zero the instrument on all ranges immediately prior to making critical field measurements. The zeroing process takes out residual zero errors in the Hall probe and the instrument's preamplifier "front-end".

The instrument must be zeroed if it has not been powered for 30 days or more, as there is a possibility that its memory back-up may have failed. Zeroing is mandatory if a different probe is to be used since the instrument was last zeroed. You should also zero the instrument when using it for the first time. The ac ranges must also be zeroed individually.

Before zeroing the system, connect up and apply power as described in sections 3.2 and 3.3. Allow 30 minutes for the instrument and probe to stabilize.

For absolute zeroing, place the probe in a zero-field region, either in a zero field chamber or inside a suitable magnetic shield, so that the probe is shielded from the earth's magnetic field and other stray fields.

If desired, a relative zero setting may be done; the instrument is zeroed after the probe is placed in its measurement position. Thus any ambient field is automatically subtracted from subsequent measurements. The probe should not be moved once zeroing is complete. About 5% of full-scale may be zeroed out without reducing full-scale span below specification.

The zero field reading is affected slightly by the presence of metal against the probe's back surface. If the probe is to be used clamped to a metal surface, or in a probe holder, it should be zeroed in the same situation. Allow the probe to stabilize thermally for a minute or two before zeroing.

A range is selected by pressing the RANGE key. The four range indicators show the selected range. The RANGE key selects the ranges in turn in the sequence 0.3, 0.6, 1.2, and 3.0 tesla. If a single-range probe is in use, the RANGE key will have no effect.

The zeroing process is implemented by pressing and releasing both keys together. Alternatively, press and hold either key while pressing the other key twice momentarily. The display will read **Zero** for a moment, indicating that zeroing has occurred.

The zeroing process should now be repeated for all the remaining ranges. Press the RANGE key to select another range, and zero this range by pressing both keys together, as above. After changing ranges, wait 1 or 2 seconds before zeroing. Continue until all the ranges have been zeroed.

To zero the ac ranges, first select the ac mode by pressing the MODE key once. "A" will appear at the left of the main display.

Now perform the zeroing function on all ranges, as described above.

Because the ac measurement circuitry has a 0.2 second time constant, allow the display to settle after changing ranges before zeroing.

Return to normal dc field display by pressing the MODE key 4 times. Once the zeroing process has been completed, the internal processor will apply the appropriate correction to whichever range is selected. It is recommended that the instrument be re-zeroed if the ambient temperature has changed significantly.

4.2 INSTALLING THE PROBE

Group3 Hall probes are built to be as robust as possible for a small, precision device. However, it is most important that certain precautions be taken when handling and installing probes so that they are not damaged or destroyed, and to preserve their accurate calibration.

Mount the probe head so there is no pressure which will tend to bend or depress its ceramic rear surface. If the probe head is clamped, make sure the surface in contact with the ceramic is flat and covers the whole of the ceramic surface. Do not apply more force than is required to hold the probe in place. Any strain on the ceramic will alter the probe's calibration, and excessive force will destroy the Hall element inside.

When the probe head is mounted, the cable should be clamped firmly nearby so it cannot be torn away from the probe head if accidentally pulled. The flexible section adjacent to the probe head can be carefully folded to allow the cable to come away in any direction, but avoid repeated flexing of this section.

Keep the cable out of the way of foot traffic. Do not pinch the cable, or drop sharp or heavy objects on it. A severed cable cannot be re-joined without altering the probe's performance, and requires factory repair and re-calibration.

The probe can be fitted to a Group3 probe holder, part no.17000050 for the LPT-141 and LPT-231, part no.17000081 for the MPT-141 and MPT-231. Probe holders which orient the probe head to the axial position are also available from Group3 suppliers. The holders protect probes and provide additional cable strain relief. Alternatively, the probe can be clamped using the machined detail in each side of the metal cap.

The probe will measure the component of the field which is normal to the flat surface of the probe head. The point of maximum sensitivity is marked by a target printed on the top of the probe head. A positive indication will be obtained when the magnetic field vector enters this side of the probe. The target represents the tail of the vector arrow.

Magnetic field convention is that field lines are directed from an N pole to an S pole. Fig. 8 gives the dimensions of the two styles of probe, and shows the position of the most sensitive point.

If the exact direction of the magnetic field is unknown, its magnitude can be measured by putting the DTM in the peak hold mode, and slowly rotating the probe. As the probe turns and the measured field rises and falls, its maximum value is held on the display. See section 4.4.2.

LPT-141 and LPT-231

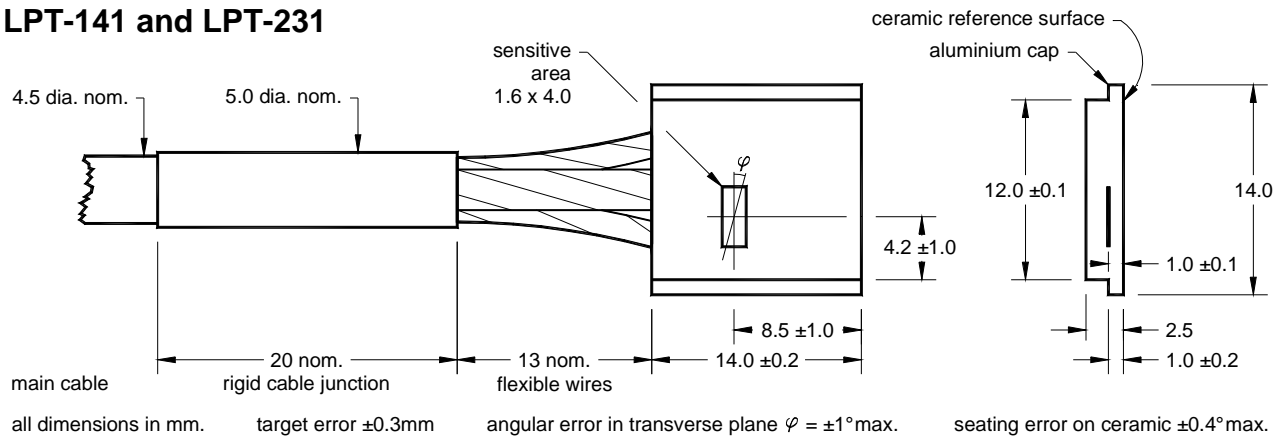

MPT-141 and MPT-231

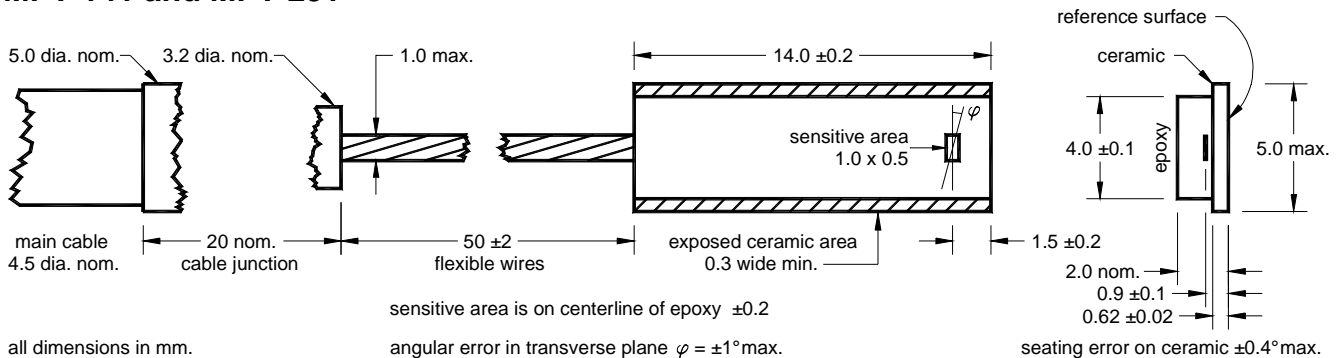

Fig. 8. Probe Dimensions

4.3 READING THE FIELD VALUE

The field value is read directly off the display. A negative sign indicates that the field direction is opposite to that described in section 4.2. For maximum resolution, select the lowest range which will display the field value. See sections 4.1 and 4.4 for range selection instructions. If the field reading is greater than full-scale, the message **o'rAnGE** will be displayed. Change to a higher range until the message clears. The field may be displayed in tesla or gauss, with the appropriate indicator showing the units in use. To change the units, see section 3.6.

4.4 DISPLAY MODES, USING THE FRONT PANEL KEYS

4.4.1 The Keys

Two front panel keys are used to control the teslameter. Changes of state occur as a key is released, not as it is depressed.

The MODE key, used on its own, rolls the instrument through the various operating modes in sequence: dc field, ac field, peak hold field, peak hold ac field, and probe temperature, as described in 4.4.2 below.

The RANGE key selects the range without changing the display mode.

The keys are pressed together (at the same time) to zero the display.

The same action is used to reset the display in the peak hold mode.

4.4.2 Operating Modes

a. Field (dc) display.

Four ranges, 0.3, 0.6, 1.2, and 3.0 tesla full-scale, are selected in sequence by pressing the RANGE key. Four range indicators show the range in use. If a high sensitivity probe is connected to the teslameter, the actual full-scale ranges are one tenth of those shown above, i.e. 0.03, 0.06, 0.12, and 0.3 tesla.

The magnetic field measurement is displayed with up to seven digits.

A minus sign is added to indicate reverse polarity fields.

Press the keys together to zero the display. The display shows **ZErO**.

Field reading is filtered if selected by the internal switch - see p.3-9.

b. AC field measurement, ranges and zeroing as above.

Shows the value of time-varying component of field.

This mode is indicated by A appearing in the left-hand display character.

c. Peak hold display, ranges as above.

Displays maximum field measurement taken, either polarity, since entering the mode, or since last reset.

HOLD indicator shows peak hold mode is operating.

If filtering is on, the filtered field value is held.

Reset is performed by pressing both keys together.

The peak value is also reset if the field polarity changes.

d. Peak ac measurement. Combination of b. and c. above.

e. Probe temperature display in degrees Celsius.

4.4.3 Display Messages

Power up message

The message **Group3** appears in the display for 2 seconds when the teslameter is first powered, or when a serial command restarts the operating software (see section 4.5.2).

No Probe

The message **noPrbE** is displayed if the Hall probe is disconnected from the instrument. While the message is visible, all key functions are disabled.

No Temperature Sensor

The message **noPrb°C** is displayed for 2 seconds after the Group3 power up message if the probe is not a temperature corrected type, e.g. LPT-130, LPT-230, MPT-132, MPT-230. The message is also displayed if the MODE key is pressed to display what would have been the probe temperature reading. This message warns the user that the field reading is not temperature corrected, and therefore the accuracy will be less than would be obtained with a temperature corrected probe (LPT/MPT-141/231).

Temperature Error

The message **Error°C** is displayed in place of the temperature reading if a temperature corrected probe is in use but there is a fault with the probe's temperature sensor or associated wiring or circuitry. Again, this is to warn the user that the field reading will not be to full accuracy.

Over-range

The message **o'rAnGE** appears when the DTM is displaying dc or ac field or is in peak hold, if the field measurement exceeds the instrument's input capacity. To clear the over-range message, select a higher range or reduce the magnetic field at the probe, or both if necessary. During over-range, all key operations are locked out, except for range selection.

Overflow

The message **o'FLo** is displayed in dc or ac field modes, or in peak hold mode, if the computed value of the field reading exceeds the capacity of the display, that is, if the number to be displayed is outside the range ± 99999.9 . In overflow, the instrument is not over-ranged, but rather the computed reading is too large to be displayed. However, if over-ranging occurs at the same time as overflow, then the over-range message is displayed preferentially. The usual cause of overflow is a large calibration factor, scale factor, or offset entered through the serial port. See section 4.5.2.

Reset

The message **rESEt** appears for 1 second when defaults are reloaded, either by a CTRL X command, or by switching S2-8 ON.

No Local Control

The message **noLOCAL** appears if a key is pressed when local control is locked out by the SO1 command. See Table 9 in section 4.5.2.

Address setting display

With the teslameter in dc field display mode, when the MODE key is pressed twice very quickly the display shows **Addr nn** where *nn* is the address of the teslameter as set on switches S1-1 through S1-5. Press the mode key once again to cancel this display.

4.5 USING THE SERIAL INPUTS AND OUTPUTS

4.5.1 Serial Connections

The three bi-directional serial input/output ports at the rear of the teslameter can be used in various ways to connect the device to external equipment for data logging and systems applications. Sections 3.4 and 3.5 give information on making connection to the ports and configuring the signal flow.

In systems containing more than one teslameter or other compatible Group3 device, the serial data path can be configured in an arrangement called the Group3 Communication Loop (G3CL). This allows convenient communication to up to 31 devices from a single computer or terminal without the need for a multiplexer.

The G3CL is a communication protocol defining hardware, electrical and fiber optic signal parameters, and a command structure based on the ASCII code. All the commands applicable to the teslameter are defined in Table 9 below.

In the G3CL a message from external equipment (computer, terminal, modem etc.) is sent to the first device in the loop. This device retransmits the message to the second, and so on around the loop, until finally the last device sends the message back to the external unit. Thus the system verifies that all devices are active and have listened to the message. See Fig. 9.

Each device is assigned a unique address in the range 0 to 30, as set on the internal switches (see section 3.6). When connected in a loop containing more than one device, the devices must be set by means of an internal switch not to initiate communications themselves. They may only respond to commands from the host unit. In the teslameter, switch S2-1 must be OFF.

All Group3 devices with serial communication are fitted with fiber optic transmitters and receivers as a standard feature. Fiber optic cabling is particularly valuable when the loop runs in the vicinity of electrically noisy equipment, or when voltage isolation is required. The system uses the Hewlett-Packard HFBR-3500 series fiber optic cables. Individual cable sections between devices may be up to 60 metres in length. A Group3 model FOR repeater can be used to extend communications. Use a Group3 model FTR fiber optic to RS-232C adaptor to connect the fiber optic cables to a standard 25-way D-type RS-232C receptacle on your computer or terminal.

Electrical serial data connections to the RS-232C standard are provided on Group3 serial devices. There are two possible configurations of the loop using electrical signals, as shown in Fig. 9. One arrangement uses the RS-232 connection between the host equipment and one of the devices on the loop. The rest of the loop is connected via the G3CL ports, either electrical or fiber optic, or a mixture.

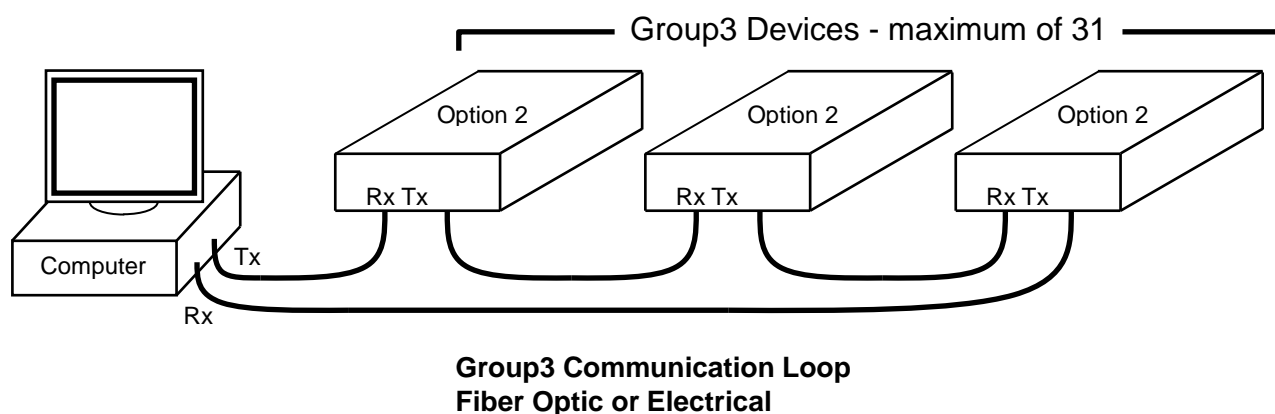
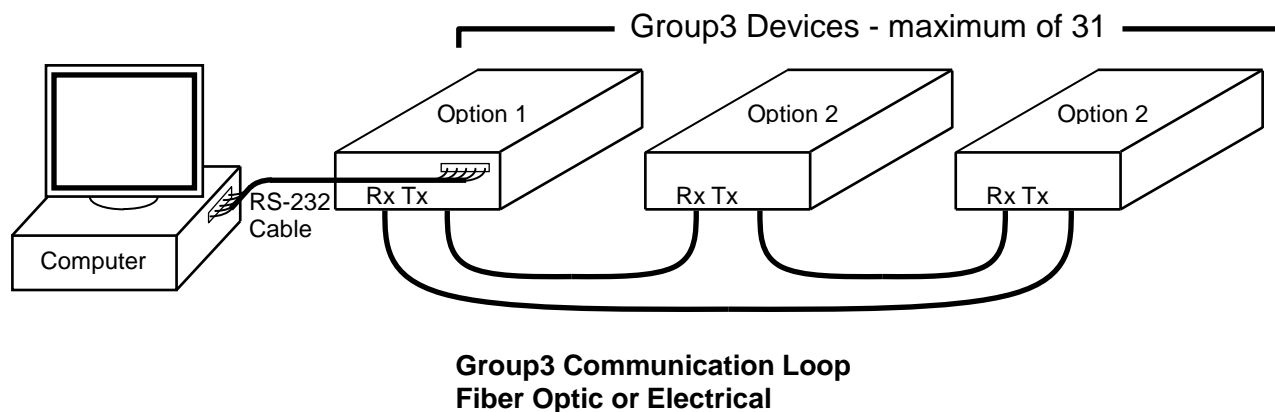

Fig. 9. G3CL - Alternative Configurations

The second arrangement uses the G3CL ports on every device. Observe the option jumper settings required as shown in Fig. 4, section 3.5.2. Note that the fiber optic and electrical G3CL ports are functionally identical and completely interchangeable in use.

4.5.2 DTM-151 Serial Commands

The commands which can be used with the teslameter, either as a single unit or in a G3CL of various Group3 devices, are set out in Table 9 below. In order to gain familiarity with the commands, it is recommended that you connect the teslameter to a terminal. The commands can then be typed in from the keyboard, and the responses observed on the terminal's screen.

The commands are in the form of one to three characters, in some cases followed by a decimal number represented by n in the table. Such numeric commands must be terminated by a carriage return <cr> character. If no number is entered where one is expected, the command is ignored. A decimal point is not required in whole number entries. Numerical values entered by commands are retained in non-volatile memory when power is off. Default values shown below apply after system reset command CTRL X or if S2-8 is ON. The processor automatically executes a reset if the memory back-up has failed after more than 30 days without power applied.

Switch-selectable defaults are instated on power-up, reset, and when a switch setting is changed. See Table 4, section 3.6.

All responses from the teslameter start with a space character. Decimal numbers include a decimal point. Some are in exponential format.

If an error message is returned, the complete command must be re-entered.

Table 9. DTM Serial Commands

command	description
An	Address - indicates to the device of address n (n = 0 to 30) that all following commands are addressed to it.
B<text><cr>	Displays ASCII text on teslameter display; 7 characters maximum.
B<cr>	Cancel text mode, return to normal display.
Cn	Calibrate - calls up the calibrate function and defines the current field measurement as equal to the entered value n. Command applies to the range selected only. Separate calibration factors are stored for each range. Default: field measurement not modified (calibration factor = 1).
D0	Turns OFF digital filtering.
D1	Turns ON digital filtering. Default set by S2-7.
EC	Erase calibration - sets calibration factor to 1 on current range.
EL	Erase scale factor - sets scale factor to 1 (all ranges).
EO	Erase offset - sets offset to 0 (all ranges).
EP	Erase (reset) peak hold field value.
EZ	Erase zero - cancels zero correction on current range.
F	Field reading - requests a field reading from the teslameter.
GA	General function AC - puts teslameter in ac field measurement mode.
GD	General function DC - puts teslameter in dc field measurement mode.
GC	General function Continuous - teslameter measures continuously.
GV	General function Triggered - teslameter measures when triggered by V.
IC	Inspect calibration factor - Returns calibration factor as mantissa and exponent.
ID	Inspect digital filtering status - returns 0 for OFF, 1 for ON.

IG	Inspect general function - returns two letters: D for dc field mode or A for ac mode, followed by C for continuous or V for triggered measurements.
IJ	Inspect filter factor - returns filter factor as mantissa and exponent.
IK	Inspect sampling interval - returns interval in seconds between output field readings. 0 implies readings sent at maximum rate.
IL	Inspect scale factor - returns current scale factor.
IN	Inspect display mode – returns: H for hold display N for normal field display T for temperature display
IO	Inspect offset - returns current value of offset.
IR	Inspect range – returns: 0 for 0.3 tesla range 1 for 0.6 tesla range 2 for 1.2 tesla range 3 for 3.0 tesla range
IY	Inspect window - returns current value of window within which digital filtering operates.
IZ	Inspect zero - returns current zeroing offset added to field values.
Jn	Filter factor - enters filter factor n. Default n = 41. n = 0 or 1, no filtering n > 1, filtering more severe as n increases, max. 65534. 0 < n < 1, reading overshoots.
Kn	Sampling interval - enters interval between output field values. Default n = 0, every reading sent, rate is 10 samples/second; n = any integer, time in seconds between output field values, maximum n = 65534 (approx. 18 hours).
Ln	Scale - computes a scale factor to make the field reading equal to the entered value n. The one scale factor applies to all ranges. The computed scale factor may be in the range -9.9999 to 9.9999. Default: field measurement not modified (scale factor = 1).
NH	Display mode: hold - teslameter display shows peak dc or ac field.
NN	Display mode: normal - teslameter display shows current field value.
NT	Display mode: temperature - teslameter display shows temperature.
On	Offset - calls up offset mode and enters offset, which is added to all field readings. Default = 0. n in range -79999.9 to +79999.9. The one offset applies to all ranges.
P	Peak hold field - requests a peak field reading from the teslameter.
Q	Test teslameter front panel display.
R0	Range selection, selects 0.3 tesla range.
R1	Range selection, selects 0.6 tesla range.
R2	Range selection, selects 1.2 tesla range.
R3	Range selection, selects 3.0 tesla range.
SCn	Set calibrate - enters calibration factor n for the selected range; Like Cn, but enters factor, not desired field reading. Default n = 1.

SE0	Turn OFF echo of every character received.
SE1	Turn ON echo of every character received. Default set by S2-4.
SFn	Put in a simulated field to replace the measured reading. X cancels.
SLn	Set scale - enters scale factor n for all ranges; Like Ln, but enters factor, not desired field reading. Default n = 1.
SM0	Send mode: field readings sent when requested by F command only.
SM1	Send mode: field readings sent at intervals defined by Kn command. Default for address 0 (S1-1 to S1-5 OFF) set by S2-1.
SO1	Puts teslameter in local lockout mode. The keys become inactive. Pressing the keys gives display message noLOCAL.
SO0	Restores local operation.
STn	Put in a simulated temperature to replace the real reading. X cancels.
SU0	Turns OFF units symbol sent after field and temperature readings.
SU1	Turns ON units symbol sent after field and temperature readings. Default set by S2-6.
SWAn	Put in a simulated raw field at the ADC output. X cancels.
SWE _n	Put in a simulated raw field after EEPROM calibration. X cancels.
SWZ _n	Put in a simulated raw field after zeroing. X cancels.
SZ _n	Set zero - enters a zero offset n for the selected range.
T	Temperature - requests a temperature reading from the teslameter.
UFG	Units: field values displayed and sent in gauss.
UFT	Units: field values displayed and sent in tesla. Default set by S2-5.
V	Triggers field measurement after triggered operation selected by GV.
WA	Raw field - returns uncalibrated field reading direct from ADC.
WE	Returns raw field reading after teslameter internal calibration.
WZ	Like WE, but field reading has user-entered zero offset applied.
X	Cancels simulated field and temperature.
Y _n	Window - enters n = window within which digital filtering occurs. Default 1 gauss. Maximum n = 65534.
Z	Zeroing - calls up zeroing mode and defines current field reading as zero for selected range only. The ranges are individually zeroed. Default sets zeroing offset to zero.
CTRL B	Returns single hex character 0 through F indicating the position of the baud rate selection switch; once the command has been given, changing the switch position does not alter the baud rate until some other command is sent.
CTRL D	Returns a 16-bit binary number representing the states of the 16 DIP switches, 0 = OFF, 1 = ON; once the command has been given, changing the switches does not alter the teslameter operating mode until some other command is sent.
CTRL U	Restarts operating software as if teslameter had been freshly powered up.
CTRL X	Reload defaults - all default values reinstated. Message RESET is sent.

4.5.3 Serial Output Messages

The following error messages are transmitted under the circumstances described:

INVALID COMMAND ENTRY - the command entered did not comply with Table 9.

NUMBER TOO BIG - the number entered in a command was too big.

POSITIVE NUMBER REQUIRED - erroneous entry of minus sign.

DIVIDE BY ZERO - a command entered a number which gave this arithmetic error.

RESET - defaults were reloaded by CTRL X command or switching S2-8 ON.

NO TEMPERATURE PROBE - a temperature reading was requested from a non-temperature corrected probe.

BAD TEMPERATURE READING - a temperature reading was requested from a temperature corrected probe, but the temperature sensor or associated circuitry is giving an invalid reading.

FRAMING ERROR - the wrong number of bits was sent in one or more characters of the last command.

OVERRUN ERROR - characters were sent too quickly for the teslameter to process. The teslameter contains a FIFO buffer which can accept more than 30 command characters in an unbroken stream.

PARITY ERROR - a mismatch in parity in one or more characters received.

DATA CARRIER NOT PRESENT - handshake pin 4 (DCD) has gone low; commands cannot be accepted in this state. See Fig. 2, section 3.5.2.

FIXED RANGE PROBE - an attempt was made to change the range with a single range probe connected to the teslameter.

NO PROBE - a field reading was requested when a probe was not connected.

OVERFLOW - the computed field value was outside the range ñ99999.9.

OVER RANGE - the current field being measured is too high for the selected range.

4.5.4 Some Examples Using the Commands

With the teslameter connected to a source of serial data as described in Sections 3.4 and 3.5, send the character Z to the teslameter. This will zero the range currently selected. To check which range is current, send IR to the teslameter. The response will be 0 for the 0.3 tesla range, 1 for 0.6T, 2 for 1.2T, and 3 for the 3.0T range. In order to change the range, send R followed by a single numeral as defined above, e.g. R2 will select the 1.2T range, and IR will return 2 to confirm the range selection. Always wait a second or two after a range change before zeroing.

To select the ac mode, send GA. To return to dc mode, send GD.

To check which mode the teslameter is in, send IG. This will return D for dc, A for ac, plus either C or V for continuous or triggered mode.

Select and zero each range in turn. The following character strings may be used:

Zero all ranges: R0/ZR1/ZR2/ZR3/Z , where / indicates a 1 to 2 second pause.

Select and zero all ac ranges, then return to dc mode: GAR0/ZR1/ZR2/ZR3/ZGD.

If a single range probe is in use, attempts to select another range will return the message "FIXED RANGE PROBE".

The command F will return the field value as measured by the selected range.

Detailed descriptions of the digital filtering and triggering functions are given in Sections 4.6 and 4.7.

4.6 DIGITAL FILTERING

The digital teslameter software includes a digital filtering algorithm which may be invoked by an internal switch or by remote command. See sections 3.6 and 4.5.2. Filtering is useful for smoothing out small fluctuations in the field reading.

In order to speed up the response to large field changes when filtering is on, a window can be set to define a band about the current displayed field value. Filtering will only occur while the unfiltered field value remains within the window. If the field value changes rapidly enough, the filtered field reading will not be able to follow fast enough to keep the unfiltered value within the window, and filtering is temporarily disabled. This allows the field reading to follow large rapid field changes, while providing good filtering of constant or slowly varying fields.

The window width can be set using the Y command. See Table 9, section 4.5.2. The value entered is the half-window on either side of the current field reading. The default value on system reset is 1 gauss, for a total window width of 2 gauss, independent of range.

The digital filter takes the field readings before processing by zero, calibrate, offset, and scale functions, and filters the values by performing the following computation:

$$F(\text{new}) = F(\text{old}) + \frac{F - F(\text{old})}{J}$$

where F(old) is the previous field reading display
F(new) is the updated field reading display
F is the most recent unfiltered field reading
J is the filter factor.

The effective time constant of the filter is dependent upon both the rate at which field measurements are made and the value of J, according to the formula:

$$T = P / \{\ln[J/(J-1)]\}$$

where T is the filter time constant
P is the period between field measurements.

Field measurements are made at a fixed rate of 10 per second, so $P = 0.1$. A default value of 41 for J is effective when the DTM is reset with the CTRL X command or S2-8. This gives an effective time constant of 4 seconds. The filter time constant may be changed by entering a new value of J using the Jn command. See section 4.5.2.

4.7 TRIGGERED OPERATION

Triggering allows one or more teslameters to make synchronized field measurements on demand.

The teslameter is set for triggered operation by entering the command GV.

To initialize a measurement, enter the command V. This is the only command which is simultaneously obeyed by more than one device on the loop; the V is not to be preceded by an address command; all devices which have been set for triggered operation by the GV command will respond to the V. The new measurement will immediately appear on the teslameter display, and can be read on the serial output by entering the F command.

The following sections describe details of triggered operation.

4.7.1 Automatic transmission of new measurement

When a teslameter is used on its own as the only device in a G3CL, the field measurement triggered by V will then be transmitted immediately if the device has been set for continuous transmission by the SM1 command or if S2-1 is ON with the address set to zero (see section 3.6).

If the teslameter has been initialized by the SM0 command, or if S2-1 is OFF, or if the device address is not zero, the new measurement will not be transmitted until the F command is entered.

In multi-device systems, each teslameter should be set NOT to send the new reading automatically; each device must be read out individually by addressing it (An) then requesting a field value using F.

4.7.2 Digital filtering with triggered operation

If filtering is ON, then each time a measurement is triggered the filtering algorithm will calculate a new field value for display and transmission, as described in section 4.6.

The effective time-constant will depend on the timing of the V commands.

If the field values obtained on triggering are required to reflect only the field at the time of triggering and not contain any history, then filtering should be turned OFF.

4.7.3 Triggered operation timing

The teslameter stores a new field value from 0 to 10ms after the V is received. After storing, computations are done.

The new field value is ready no later than 175msec after the V command is received. Do not request the new field value (using F) sooner than 175msec after the V command, or the old field value may be sent.

If the teslameter is set for automatic transmission of the new value (section 4.7.1), transmission will start a maximum of 175ms after the V. Just the one triggered reading is sent on each V command.

4.7.4 When the V command is ignored

The V command is ignored by teslameters which have not been initialized for triggering by the GV command.

The V command is ignored by teslameters which have been initialized for triggering, if the command is received while the device is still in the process of making a measurement in response to a previous V command.

4.7.5 Zeroing while in triggered mode

If the teslameter is zeroed, either with the keys or by remote command, while in the triggered mode, a new zero offset will be calculated and stored, using the last field measurement made. The effect of the zero operation will be reflected in the next field measurement, when the V command is given.

To ensure the most accurate zero, it is best to place the teslameter in continuous mode with filtering on, allow time for the display to settle, then give the zero command.

The unit will zero correctly in triggered mode if first the V command is given while the probe is in zero field with filtering off; then the Z command (or pressing both keys together) will zero the instrument.

5 TECHNICAL

The schematics, component overlays, and parts lists of the four circuit boards in the DTM-151 serial I/O teslameter and probe are provided for general reference. It is not recommended that the user attempt repair or servicing because in many cases replacing parts will affect the calibration of the instrument. In case of trouble or malfunction we strongly recommend that the user first contact the local distributor or Group3 directly for advice as to the best procedure for addressing the problem. Group3 may be contacted at the address below:

Group3 Technology Ltd.,

Physical address: 2 Charann Place, Avondale, Auckland 1026, New Zealand.

Postal address: P.O. Box 71-111, Rosebank, Auckland 1348, New Zealand.

Tel. +64 9 828 3358 Fax +64 9 828 3357.

email: info@group3technology.com

website: <http://www.group3technology.com>

diagram	page
Display Board Schematic	5-2
Display Board Component Overlay	5-3
Display Board Parts List	5-3
Probe Plug Board Schematic	5-4
Probe Plug Board Component Overlay	5-5
Probe Plug Board Parts List	5-5
Processor Board Schematic	5-6
Processor Board Component Overlay	5-7
Processor Board Parts List	5-8
Analog Board Schematic	5-9, 10
Analog Board Component Overlay	5-11
Analog Board Parts List	5-12, 13

The remainder of this chapter has been removed.

**This chapter will be made available upon request
and at the discretion of Group.**

GROUP3 TECHNOLOGY LTD

LIMITED WARRANTY

Group3 Technology Ltd. (hereinafter called the Company) warrants instruments and other products of its manufacture to be free from defects in materials and workmanship that adversely affect the product's normal functioning under normal use and service for a period of one year from the date of shipment to the purchaser.

The obligation of this warranty shall be limited to repairing or replacing, at the discretion of the Company and without charge, any equipment which the Company agrees is defective as set out above within its warranty period. The Company will reimburse lowest freight rate two-way charges on any item returned to the Company's factory or any authorised distributor or service centre, provided that prior written authorization for such return has been given by the Company.

This warranty shall not apply to any equipment which the Company determines to have become defective owing to mishandling, improper installation, alteration, negligence, inadequate maintenance, incorrect use, exposure to environmental conditions exceeding specifications, or any other circumstance not generally acceptable for equipment of a similar type.

The Company reserves the right to make changes in design without incurring any obligation to modify previously manufactured units.

No other warranties are expressed or implied, including, but not limited to, the implied warranties of merchantability and fitness for a particular purpose. The Company is not liable for consequential damages.

Group3 Technology Ltd - DISTRIBUTORS & REPRESENTATIVES

European Region

United Kingdom

Pulse Power & Measurement Ltd

65 Shrivenham Hundred Business Park
Watchfield, Swindon, Wiltshire, SN6 8TY, UK
Tel: +44 (0)1793 784389 Fax: +44 (0)1793 784391
email: sales@ppm.co.uk website: www.pppm.co.uk

Denmark, Sweden, Norway, Finland, Iceland, Belgium, Holland, Italy, Turkey, Russia, India

Danfysik A/S

Møllehaven 31, P.O. Box 29, DK-4040 Jyllinge, Denmark.
Tel. +45 4679 0000 Fax +45 4679 0001 Contact: Erik Steinmann
email: es@danfysik.dk website: www.danfysik.com

Germany, Poland, Czech & Slovak Republics, Ukraine

Schaefer Technologie GmbH

Mörfelder Landstrasse 33, D-63225 Langen, Germany.
Tel. +49 6103 30098-0 Fax +49 6103 30098-29 Contact: Martin Schaefer
email: info@schaefer-tec.com website: www.schaefer-tec.com

Switzerland, Austria

Schaefer-Tec AG

Badimatte 21, Postfach 431, CH-3422 Kirchberg, Switzerland
Tel. +41 34 423 70 70 Fax +41 34 423 70 75 Contact: Martin Bossard
email: ch@schaefer-tec.com website: www.schaefer-tec.com

France, Spain, Portugal

Schaefer-Techniques Sarl

1, Rue du Ruisseau Blanc, F-91620 Nozay, France
Tel. +33 1 6449 6350 Fax +33 1 6901 1205 Contact: Christophe Dubegny
email: info@schaefer-tech.com website: www.schaefer-tech.com

Italy

Schaefer Italia SRL

Via Minzoni, 57, I-45100 Rovigo, Italy
Tel. +39 0425 460 218 Fax +39 0425 462 064 Contact: Paulo Bariani
email: italia@schaefer-tec.com website: www.schaefer-tec.com

China

MT Electronic Co. Ltd.

Room 503, No.24 Building Jing Tong Yuan, Sunny Uptown International Department,
Chao Yang District, Beijing, China 100024
Tel./Fax +86 10 6570 0095, mobile: +86 130 0116 1549, Contact: Liang Qing (Rosalind)
email: lqrosalind@yahoo.com.cn website: www.mt-elec.com

India

Transact India Corporation

5/1A, Grants Building, Arthur Bunder Road, Colaba, Mumbai 400 005, India
Tel. +91 22 2285 5261, or 2283 4962 extn 22, or 2202 8735 Fax +91 22 2285 2326
email: sales@transact.co.in Contact: Arish Patel arish@transact.co.in direct dial +91 22 563 6486

Israel

Scientific Products & Technology 3000 Ltd.

P.O. Box 1425, Rosh Ha'Ayin 40850, Israel
Tel. +972 3 901 4479 Fax +972 3 901 4481 Contact: Rafael Thaler
email: info_spt@netvision.net.il website: www.spt.co.il

Japan

Hakuto Company Ltd., Scientific Equipment Department,

1 - 13, Shinjuku 1-chome, Shinjuku-ku, Tokyo 160-8910, Japan
PO Box 25 Tokyo Central 100-8691
Tel. +81 3 3225 8051 Fax +81 3 3225 9011 website: www.hakuto.co.jp
Contact: Mr Tsugio Saitoh email: saito-tsugio@hakuto.co.jp
Contact: Mr Shunsuke Takahashi email: takahashi-shunsuke@hakuto.co.jp

United States & Canada

GMW Associates - magnets, magnetic instrumentation, control systems

955 Industrial Road, San Carlos, CA 94070.
P.O. Box 2578, Redwood City, CA 94064, U.S.A.
Tel. +1 650 802 8292 Fax +1 650 802 8298 Contact: Brian Richter
email: brian@gmw.com website: www.gmw.com

VI Control Systems - LabVIEW programming, control systems

2173 Deer Trail, Los Alamos, NM 87544.
Tel. (505) 662 1461 Fax (866) 422 2931 Contact: Neal Pederson
email: np@vicontrols.com website: www.vicontrols.com

Manufacturer

Group3 Technology Ltd.,

2 Charann Place, Avondale, Auckland 1026, New Zealand.
P.O. Box 71-111, Rosebank, Auckland 1348, New Zealand.
Tel. +64 9 828 3358 Fax +64 9 828 3357
email: info@group3technology.com website: www.group3technology.com